

HAFCO

SWIVEL CRANE OPERATION MANUAL



Model.
TCS-450
ORDER CODE A353

Edition No : SWC-001

Date of Issue : 12/2018

www.machineryhouse.com.au



OPERATION MANUAL

MACHINE DETAILS

MACHINE	SWIVEL CRANE
MODEL NO.	TCS-450
SERIAL NO.	
DATE OF MANF.	

DISTRIBUTED BY



www.machineryhouse.com.au
www.machineryhouse.co.nz

NOTE:

This manual is only for your reference. Owing to the continuous improvement of the HAFCO machines, changes may be made at any time without obligation or notice. Please ensure the local voltage is the same as listed on the specification plate before operating any electric machine.



NOTE:

In order to see the type and model of the machine, please see the specification plate. Usually found on the back of the machine. See example (Fig.1)

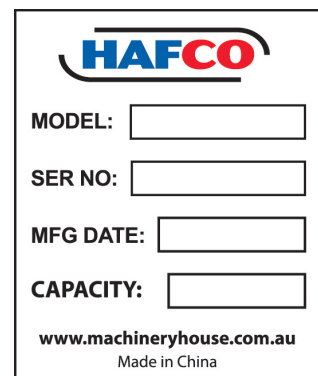

FIG.1



OPERATION MANUAL

CONTENTS:

1. GENERAL MACHINE INFORMATION	
1.1 Specifications.....	4
1.2 Identification.....	4
1.3 Overview.....	5
2. IMPORTANT INFORMATION	
2.1 General Machinery Safety.....	6
2.2 Safety Specific For Cranes.....	7
3. INSTALLATION	
3.1 Unpacking.....	9
3.2 Assembly.....	9
4. OPERATION.....	11
SPARE PARTS.....	12

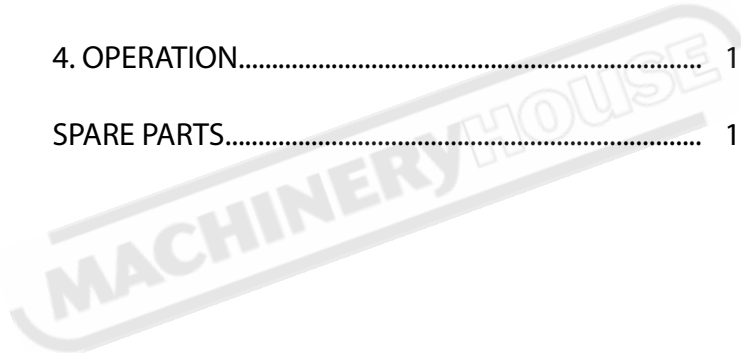



OPERATION MANUAL

1.1 SPECIFICATIONS

Order Code	A353
Model	TCS-450
Lifting Capacity - Maximum (kgs)	450
Type	Hydraulic - Manual
Lift Capacity Pin Locations (Kgs)	450 & 230
Continuous Manual Rotation (deg.)	360
Max. Lifting height (Base to hook):(mm)	2100
Min. Lifting height (Base to hook):(mm)	580
Maximum Reach (mm)	1070
Minimum Reach (mm)	650
Base Plate (mm)	268 x 268
Vertical Support (mm)	70 x 70
Extension Arm Support (mm)	70 x 70
Hydraulic Ram (tonne)	3
Overall Height - Lowest Position (mm)	1350
Nett Weight (kgs)	50

1.2 IDENTIFICATION

A	Main Support
B	Boom
C	Boom Extension
D	Hook and Chain
E	Hydraulic Ram
F	Pump
G	Pressure Release Valve
H	Swivel Coupling
I	Base Plate
J	Swivel Lock Handle
K	Pump Handle
L	Swivel Handle

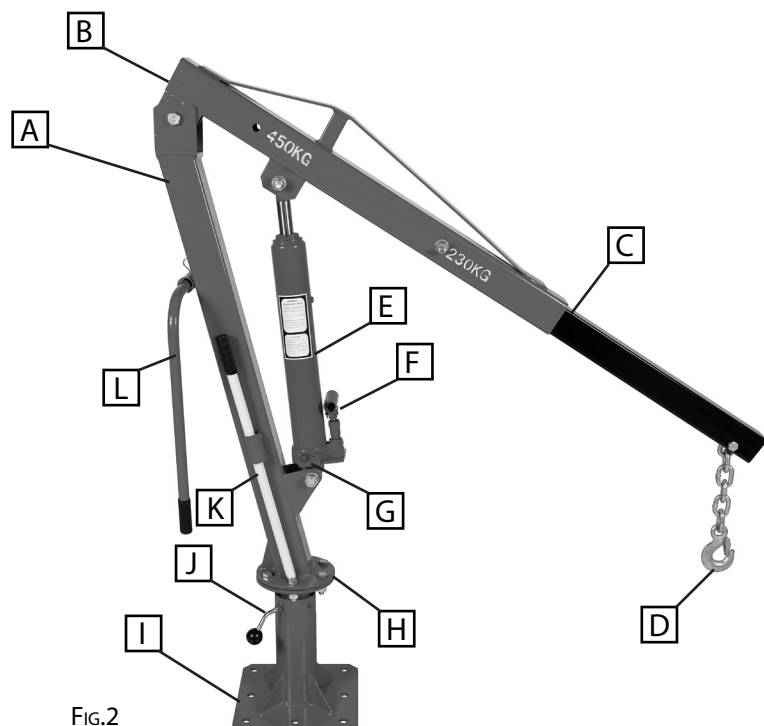
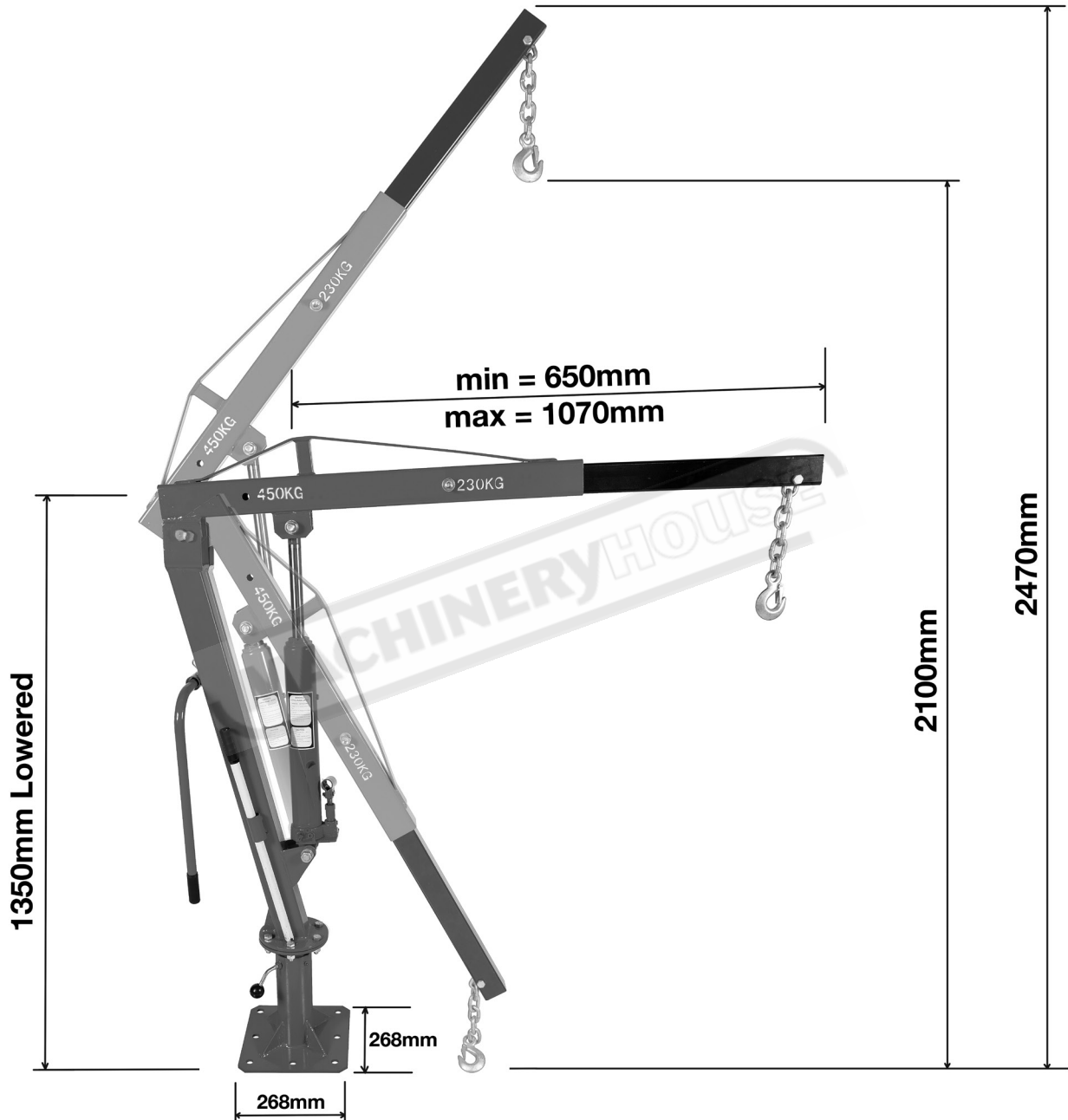

Fig.2



OPERATION MANUAL

1.3 OVERVIEW





OPERATION MANUAL

2.1 GENERAL MACHINERY SAFETY

DO NOT use this machine unless you have read this manual or have been instructed in the use of this machine in its safe use and operation



WARNING

This manual provides safety instructions on the proper setup, operation, maintenance, and service of this machine. Save this manual, refer to it often, and use it to instruct other operators. Failure to read, understand and follow the instructions in this manual may result in serious personal injury—including amputation, or death.

The owner of this machine is solely responsible for its safe use. This responsibility includes, but is not limited to proper installation in a safe environment, personnel training and authorization to use, proper inspection and maintenance, manual availability and comprehension, of the application of the safety devices, integrity, and the use of personal protective equipment.

The manufacturer will not be held liable for injury or property damage from negligence, improper training, machine modifications or misuse.



Safety glasses must be worn at all times in work areas.



Sturdy footwear must be worn at all times in work areas.



Gloves should be worn when using this machine and only removed when using the pump handle or adjusting the pressure release valve.



Long and loose hair must be contained with a net or under a hat

OWNER'S MANUAL. Read and understand this owner's manual before using the machine.

CHECK DAMAGED PARTS. Regularly inspect the machine for any condition that may affect the safe operation. Immediately repair or replace damaged or parts that are incorrectly fitted before operating.

TRAINED OPERATORS ONLY. Operators that have not been trained have a higher risk of being seriously injured. Only allow trained or supervised people to use this Swivel Crane. Never allow children to play on this swivel crane and never carry passengers



OPERATION MANUAL

2.1 GENERAL MACHINE SAFETY Cont.

WEARING PROPER APPAREL Do not wear clothing, apparel or jewelry that can become entangled in moving parts. Always tie back or cover long hair. Wear non-slip footwear to avoid accidental slips, which could cause loss of operating control.

USE CORRECT TOOL FOR THE JOB. Only use this tool for its intended purpose. Do not force the machine or its attachments to do a job for which they were not designed. Never make unapproved modifications. Modifying the machine or using it differently than intended may result in malfunction or mechanical failure that can lead to personal injury or death!

AWKWARD POSITIONS. Keep proper footing and balance at all times when operating the Swivel Crane. Do not overreach! Avoid awkward hand positions that make operating control difficult. This could increase the risk of accidental injury.

FORCING MACHINERY. Do not force the Swivel Crane. It will do the job safer and better at the rate for which it was designed.

NEVER STAND ON MACHINE. Serious injury may occur if the Swivel Crane is tipped or if crush points are unintentionally contacted

STABLE MACHINE. Unexpected movement during operation greatly increases risk of injury or loss of control. Before using the Swivel Crane verify that it is stable

UNATTENDED OPERATION. To reduce the risk of accidental injury, never leave the Swivel Crane in use while unattended.

MAINTAIN WITH CARE. Follow all maintenance instructions and lubrication schedules to keep the Swivel Crane in good working condition. A Swivel Crane that is improperly maintained could malfunction, leading to serious personal injury or death.

CHILDREN & BYSTANDERS. Keep children and bystanders at a safe distance from the work area. Stop using machine if they become a distraction.

2.2 SAFETY SPECIFIC FOR CRANES

ALWAYS:

- Be aware of "pinch points" and keep fingers and feet away
- Check there is sufficient height for ram and boom
- Be sure load is secured and cannot move from the vertical line
- Use correctly rated SWL slings or chains to secure load
- The approved lifting weight for each boom position is marked on the boom and must not be exceeded

- The cranes must only be used on smooth, hard, level surfaces.

DO NOT:

- Modify the crane
- Overload crane
- Twist or pull crane sideways
- Use rope to secure the load
- Work under a loaded crane
- Leave load suspended and unattended
- Lean a ladder against the crane



OPERATION MANUAL

2.2 SAFETY SPECIFIC FOR SWIVEL CRANES

DO NOT use this machine unless you have read the manual or have been trained and assessed to a competent level in its safe use and operation.



Safety glasses must be worn when operating this equipment



Long and loose hair must be contained when operating this equipment.



Safety footwear must be worn when operating this equipment



Close fitting/protective clothing must be worn when operating the Swivel Crane

PRE-OPERATIONAL INSPECTION:

Engine crane inspection:

- Pre-operation inspection should be done each day
- Operational and maintenance instructions to be available to the operator
- Working Load Limit(WLL) to be prominently displayed on the crane
- Checks pins and bolts are in place
- Check controls for proper response
- No signs of hydraulic fluid leaks
- No signs of cracks or damage to crane parts
- All safety devices checked to be operational

Ensure work area:

- There are no obstructions above or around the vehicle that could interfere with or obstruct the lifting procedure
- Exclusion zone in position
- Clear of overhead wires and obstructions
- Access is clear
- Lighting is appropriate.

Vehicle:

- Set parking or emergency brake and put gear shift in park
- Manual transmissions should be in lowest gear
- Vehicle ignition off with steering wheel lock on



NOTE: If unsure of the reliability of the hand brake, then the wheels should be chocked

Hazards

- Pedestrians in work zone
- Vehicles, mobile plant in vicinity
- Slippery / uneven surfaces, objects on ground
- Engine crane – vehicle uncontrolled movement /crane failure
- Hydraulic failure – crane
- Uncontrolled movement of vehicle / plant
- Fluids under pressure
- Falling objects
- Moving machine parts
- Hazardous Manual Tasks - awkward, twisting, bending positions, lifting, carrying, or lowering down objects, pushing, pulling objects.

Risks.

- Persons entering exclusion zone distracting workers
- Person/s entering exclusion zone – injured by other vehicles, equipment, etc on site
- Being run over/ struck by vehicle / mobile plant causing serious injury/ death
- Falling over on same level causing bruises, sprains, strains, fractures
- Crane failure - Crushed by the load falling
- Hit by flying / projected object
- Fluid injection injury
- Injury caused by uncontrolled swiveling of the crane



OPERATION MANUAL

3. INSTALLATION

3.1 UNPACKING

This Swivel Crane was carefully packaged for safe transport. When unpacking, separate all enclosed items from packaging materials and inspect them for shipping damage. If items are damaged, please contact your distributor.

NOTE: Save all the packaging materials until you are completely satisfied with the Swivel Crane and have resolved any issues with the distributor, or the shipping agent.

When unpacking, check to make sure that all parts shown on page 4 are included. If any parts are missing or broken, please contact the your distributor.

3.2 ASSEMBLY

Select the position on the ute, trailer or truck where the crane is to be mounted making sure that the base can be securely mounted.

NOTE: Check with the truck or ute manufacturer as to the suitability of the position chosen and what mounting requirements should be observed.

1. Thread the Swivel Lock Handle into the base, then mount the base to the floor. (Fig.3) The mounting bolts should be Hi-tensile bolts nuts and spring washers.
2. Line up the holes in the swivel coupling and mount the Main Post to the swivel coupling using the M12 x 40mm bolts, flat washers, spring washers and nuts supplied. Securely tighten all bolts and nuts

NOTE: It is important that the bolts supplied are used as they are Hi-Tensile bolts and nuts. If substitute bolts are to be used they must be Hi Tensile. Incorrect bolts could cause a failure of the crane and may cause injury or death.

3. Mount the boom to the main post by lining up the holes and using the M16 x 110mm bolt, flat washer, spring washer and nut supplied and securely tighten the bolt and nut.(Fig.5)

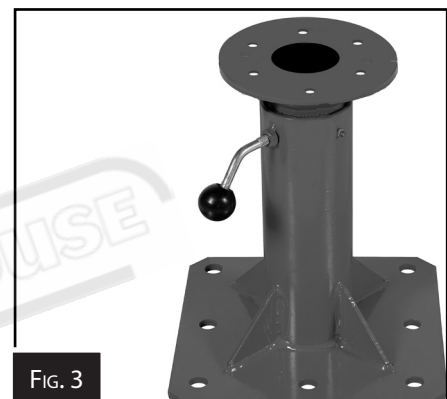

FIG. 3

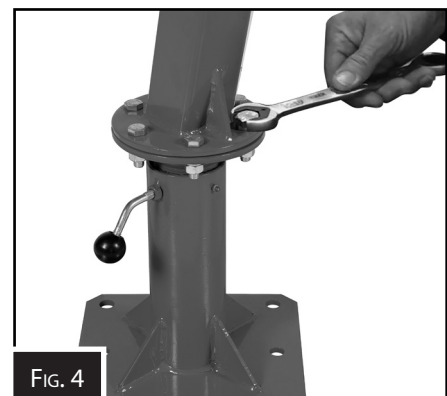

FIG. 4

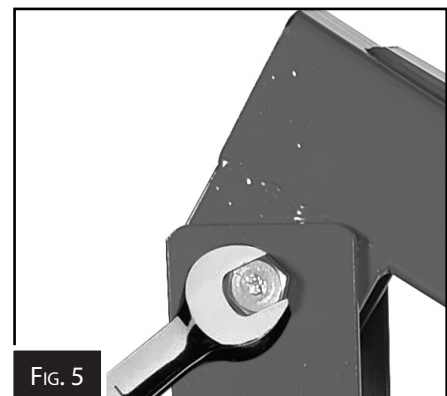

FIG. 5



OPERATION MANUAL

ASSEMBLY CONT.

4. Fix the bottom of the hydraulic jack to the main post by lining up the holes in the base of the jack and the mounting plate on the main post. (Fig. 6)
Place the M12 x 95mm bolt supplied through the holes and secure with the flat washer, spring washer and nut.
5. Lift up the boom and line up the holes in the boom with the end of the jack and secure with the M16 x 80mm bolt, flat washer, spring washer and nut supplied. (Fig. 7)
6. With the boom supported with the hydraulic jack, insert the boom extension into the boom making sure that it is secured with the M14 x 90mm bolt, flat washer, spring washer and nut. (Fig. 8)

NOTE: The boom has two mounting positions. In the shortest position the capacity of the crane is 450kgs. When the boom is extended to its maximum length the crane has a capacity of 230kgs.

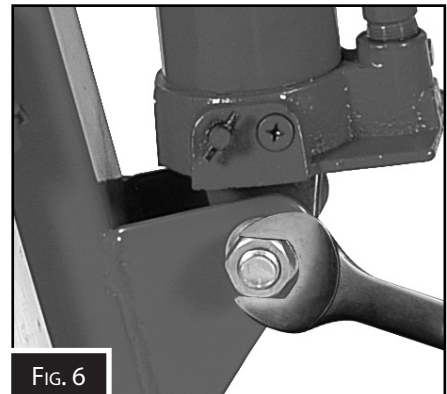

FIG. 6

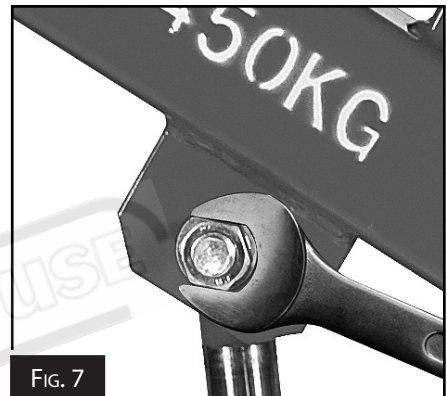

FIG. 7

WARNING

Never move or operate the crane with the boom not secured as it could cause injury to the operator or those nearby, and could cause damage to the crane or load.

7. Once the boom has been secured then mount the chain and safety hook assembly, using the M12 x 75mm bolt, flat washer, spring washer and nut supplied. (Fig. 9)
8. Once the crane is fully assembled then re-check and tighten all the bolts to ensure that they all are secure.



FIG. 8

WARNING

The capacity of the crane is based on the use of the bolts that have been supplied with the crane for assembly.



FIG. 9



OPERATION MANUAL

4. OPERATION

Before operating this Swivel Crane make sure that this manual has been read and understood by the operator.

WARNING Make sure that the vehicle's engine has been turned off and positioned on a stable flat ground, handbrake applied, chocked the wheels, and that the area around the crane is clear before commencing the lift. Be aware of any "Pinch Points"

1. Rotate boom into position over the load to be lifted and keeping it to a minimum height.
2. Close of the pressure release valve twisting clockwise on the hydraulic ram pump with the pump handle. (Fig. 10)
3. Using the pump handle supplied, operate the pump to raise the boom to the required height for positioning hook over the load. (Fig. 11)
4. Connect hook to slings around the load making sure that the beam is set to the correct position for the weight of the lift.

CAUTION Only use certified slings and lifting equipment. Failure to do so could cause injury to the operator or damage to the load.

5. When in position and ready to lift ensure that the rotary handle has been locked to stop the crane from turning during the raising of the load . Raise the boom using the pump making sure that the load is balanced.
6. Once the load is clear unlock the rotary lock and using the swivel arm (Fig.12) swivel the crane to the required position.
7. Lower the load by **SLOWLY** releasing the pressure release valve by slowly twisting anti clockwise. The rate of decent is controlled by the pressure release valve and must not be loosened anymore than two full rotations.

WARNING HAFCO advises that this crane should not be used as a mobile device when the load is lifted. The crane should be stationary at all times. Only the swivel action should be used when under load. **NEVER** work on a load whilst suspended.



FIG. 10



FIG. 11

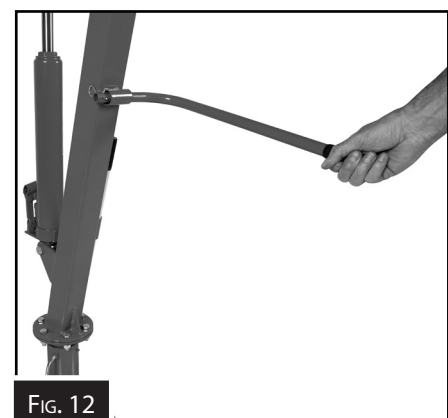

FIG. 12



OPERATION MANUAL

SPARE PARTS SECTION

The following section covers the spare parts diagrams and lists that were current at the time this manual was originally printed. Due to continuous improvements of the machine, changes may be made at any time without notification.

HOW TO ORDER SPARE PARTS

1. Have your machines **model number & date of manufacture** on hand, these can be found on the specification plate mounted on the machine
2. A scanned copy of your parts list/diagram with required spare part/s identified
3. Go to www.machineryhouse.com.au/contactus and fill out the enquiry form attaching a copy of scanned parts list.

PART NO.	DESCRIPTION	QTY.	PART NO.	DESCRIPTION	QTY.	PART NO.	DESCRIPTION	QTY.
A	CHAIN & HOOK	1	1	BOLT M12 x 75	1	11	LOCK WASHER M16	3
8	BOOM EXTENSION	1	2	FLAT WASHER M12	7	12	NUT M16	3
C	BOOM	1	3	LOCK WASHER M12	7	13	BOLT M16 x 80	1
D	MAIN POST	1	4	NUT M12	7	14	BOLT M12 x 95	1
E	HANDLE	1	5	BOLT M14 x 90	1	15	BOLT M12 x 40	6
F	JACK	1	6	FLAT WASHER M14	1	16	BEARING	1
G	JACK HANDLE	1	7	LOCK WASHER M14	1	17	"R"PIN	1
H	TURNTABLE	1	8	NUT M14	1	18	WHEEL BINDING BOLT	1
I	WHEEL HUB	1	9	BOLT 16 x 110	1	19		
J	BASE	1	10	FLAT WASHER M16	3	20		



OPERATION MANUAL

SPARE PARTS DIAGRAM

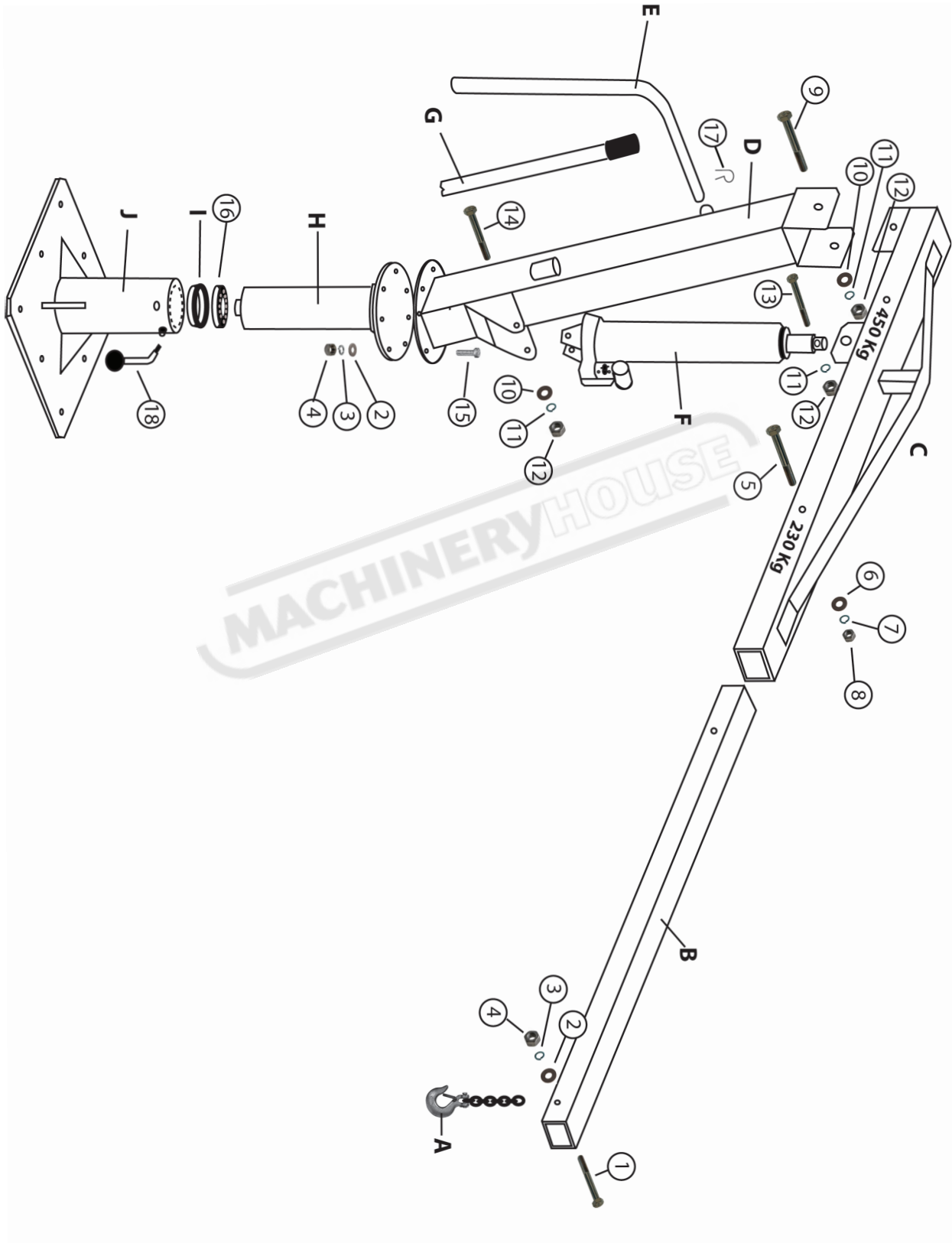



WARNING

General Machinery Safety Instructions

Machinery House
requires you to read this entire Manual before using this machine.

- 1. Read the entire Manual before starting machinery.** Machinery may cause serious injury if not correctly used.
- 2. Always use correct hearing protection when operating machinery.** Machinery noise may cause permanent hearing damage.
- 3. Machinery must never be used when tired, or under the influence of drugs or alcohol.** When running machinery you must be alert at all times.
- 4. Wear correct Clothing.** At all times remove all loose clothing, necklaces, rings, jewelry, etc. Long hair must be contained in a hair net. Non-slip protective footwear must be worn.
- 5. Always wear correct respirators around fumes or dust when operating machinery.** Machinery fumes & dust can cause serious respiratory illness. Dust extractors must be used where applicable.
- 6. Always wear correct safety glasses.** When machining you must use the correct eye protection to prevent injuring your eyes.
- 7. Keep work clean and make sure you have good lighting.** Cluttered and dark shadows may cause accidents.
- 8. Personnel must be properly trained or well supervised when operating machinery.** Make sure you have clear and safe understanding of the machine you are operating.
- 9. Keep children and visitors away.** Make sure children and visitors are at a safe distance for you work area.
- 10. Keep your workshop childproof.** Use padlocks, Turn off master power switches and remove start switch keys.
- 11. Never leave machine unattended.** Turn power off and wait till machine has come to a complete stop before leaving the machine unattended.
- 12. Make a safe working environment.** Do not use machine in a damp, wet area, or where flammable or noxious fumes may exist.
- 13. Disconnect main power before service machine.** Make sure power switch is in the off position before re-connecting.
- 14. Use correct amperage extension cords.** Undersized extension cords overheat and lose power. Replace extension cords if they become damaged.
- 15. Keep machine well maintained.** Keep blades sharp and clean for best and safest performance. Follow instructions when lubricating and changing accessories.
- 16. Keep machine well guarded.** Make sure guards on machine are in place and are all working correctly.
- 17. Do not overreach.** Keep proper footing and balance at all times.
- 18. Secure workpiece.** Use clamps or a vice to hold the workpiece where practical. Keeping the workpiece secure will free up your hand to operate the machine and will protect hand from injury.
- 19. Check machine over before operating.** Check machine for damaged parts, loose bolts, Keys and wrenches left on machine and any other conditions that may effect the machines operation. Repair and replace damaged parts.
- 20. Use recommended accessories.** Refer to instruction manual or ask correct service officer when using accessories. The use of improper accessories may cause the risk of injury.
- 21. Do not force machinery.** Work at the speed and capacity at which the machine or accessory was designed.
- 22. Use correct lifting practice.** Always use the correct lifting methods when using machinery. Incorrect lifting methods can cause serious injury.
- 23. Lock mobile bases.** Make sure any mobile bases are locked before using machine.
- 24. Allergic reactions.** Certain metal shavings and cutting fluids may cause an allergic reaction in people and animals, especially when cutting as the fumes can be inhaled. Make sure you know what type of metal and cutting fluid you will be exposed to and how to avoid contamination.
- 25. Call for help.** If at any time you experience difficulties, stop the machine and call you nearest branch service department for help.



Swivel Crane - Truck or Ute Safety Instructions

Machinery House
requires you to read this entire Manual before using this machine.

- 1. Maintenance.** Check oil levels and fill to correct oil levels if necessary.
- 2. Loading Requirements.** Check service manual to locate safe lifting support locations & verify that the item weight to be lifted, does not exceed the maximum Swivel Crane load rating. Only connect lifting hooks, chains or straps at points that can safely support the load and prevent unpredictable load swing or shift.
- 3. Swivel Crane Condition.** The Swivel Crane must be maintained for a proper working condition. Never operate a Swivel Crane that has low oil levels, damaged or worn parts. Scheduled routine maintenance should be performed on a scheduled basis. Check frame, welds, pins, chain & hook for cracks or damage. Replace if necessary.
- 4. Crushing Hazard.** Never place any part of your body in the lifting mechanism. Serious injury can occur. Never allow anyone to work under a load supported by swivel crane. Always ensure load is either supported on Truck / Ute deck or on the ground. Minimise time for load to be lowered, never leave load suspended in air.
- 5. Work area hazards.** Keep the area around the Truck / Ute & Swivel Crane to be clean from oil, tools & objects. Pay attention to other persons in the area and know what is going on around the area to prevent unintended accidents. Do not use hoist in damp or wet conditions. Do not expose to rain.
- 6. Warning Labels.** Take note of any warning labels on the machine and do not remove them.
- 7. Assembly of Base to Vehicle or Floor.** Determine where the crane will be installed into the vehicle or floor & securely fasten to the bed or the tray of your vehicle or garage floor. Caution: Contact your vehicle manufacture for mounting requirements.
- 8. Safe Surface Use.** Ensure is mounted & used on level surfaces capable of sustaining the load being lifted. Avoid using the Swivel Crane on inclines that will cause a loss of control.
- 9. Pre-Operation Safety Checks.** Never lift an object when the vehicle is in motion. Always make sure vehicle is in park, the engine is off, parking brake set and wheels are chocked before using. Do not overload beyond its rated capacity marked on the side of the boom for the corresponding boom position.
- 10. Safe Operation.** Rotate crane boom into position over the load to be lifted keeping boom to a minimum height. Using Ram pump handle to close off pressure release valve by twisting clockwise. Attach lifting chains or slings to hook making sure the device is securely attached to the load and is suitably rated to hold the weight. Place pump handle into the pump actuator and slowly pump until the crane begins to support the load being lifted. Double check the load being lifted is firmly supported by the crane, chain, sling or levelling device. Pump the pump handle to raise the working load to the desired height.

Using the rotation handle slowly swing the load to the desired lowering location. Using Pump Hand slowly open pressure release valve on pump by slowly twisting anti-clockwise until load begins to lower (Do not loosen anymore than 2 full rotations). Excessive speed or jerky motion can cause the load to slip leading to property damage or personal injury.

Note: Never leave the load suspended for long periods of time, as soon as practicable the load should be lowered.
- 11. Other Hazards.** Never allow children to play on this Swivel Crane, and never carry passengers!
- 12. Pinching.** Prevent pinching by releasing pressure in the ram leaving boom all the way down when not in use.
- 15. Call for help.** If at any time you experience difficulties, stop and call your nearest branch service department for help.

PLANT SAFETY PROGRAM

NEW MACHINERY HAZARD IDENTIFICATION, ASSESSMENT & CONTROL

Swivel Crane - Truck or Ute

Developed in Co-operation Between A.W.I.S.A and Australia Chamber of Manufactures
This program is based upon the Safe Work Australia, Code of Practice - Managing Risks of Plant in the Workplace (WHSA 2011 No10)

Item No.	Hazard Identification	Hazard Assessment	Risk Control Strategies <small>(Recommended for Purchase / Buyer / User)</small>
B	CRUSHING	HIGH	Ensure vehicle is stationary & on level surface. Ensure load is correctly slung and approved sling, chains etc are used. Keep body clear from under load. Do not exceed maximum lifting capacity. Wear safety boots. Always check around load before lowering. Check engine crane and lifting equipment for damage etc prior to use. Ensure load is lowered smoothly. Never leave the load suspended for a long period of time or unattended. Keep body parts clear between moving components of swivel crane when lowering.
D	SHEARING	MEDIUM	Keep body parts clear between moving components of swivel crane when lowering.
J	SLIPPING, TRIPPING, & FALLING	LOW	Avoid inclines, uneven or slippery surfaces when operating swivel crane under load. Ensure work area is clean and do not use in wet areas or when raining.
Plant Safety Program to be read in conjunction with manufactures instructions			



www.machineryhouse.com.au



www.machineryhouse.co.nz

Authorised and signed by:

Safety officer:

Manager:

Revised Date: 19th October 2018